

Karman vortex flow meter

PALDRA Instructions manual

PSL-5L/10L/30L

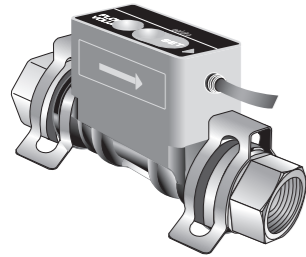

Regal Joint Co., Ltd.

1-9-49 Onodai Minami-ku Sagami-hara-shi, Kanagawa, Japan 252-0331

TEL +81-(0)42-756 7411 (Sales)
FAX +81-(0)42-752 2004 (Toll Free)

URL <http://www.rgl.co.jp>

Features

Karman vortex flow meter PSL-5L/10L/30L is the new series of flow meters to measure flow rate, with simple functions and reasonable price.

Due to compact construction it can be installed in narrow space and simple structure resulting easy maintenance, easy installation and de-installation.

Configuration and Dimensions

The electric circuit, substrate, is attached on a wetted part of the body which is covered with a cover. You find an alarm setting button and volume inside of the cover, and a cables for interface on the side.

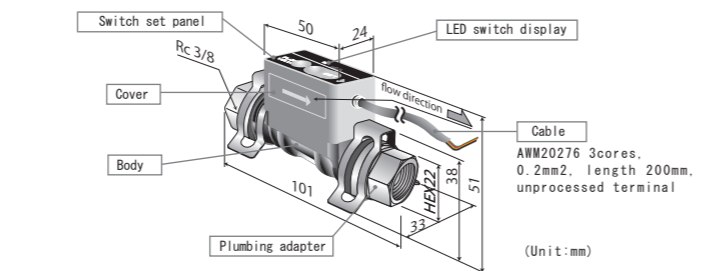

Specifications

This is the basic specification for PSL. Please read them carefully for safe use.

Models	PSL-5L	PSL-10L	PSL-30L
Rated flow range	0.5~5.0L/min	1.5~10.0L/min	5.0~30.0L/min
Fluid	Industrial water, water		
Detecting method	Karman vortex		
Fluid temperature	0~90°C (No freezing, no dewing)		
Ambient temperature	0~50°C (No freezing, no dewing)		
Accuracy	Flow rate output: ±2% full scale		
Maximum working pressure	1.0MPa		
Withstanding pressure	1.5MPa (at 20°C)		
Pressure loss (at the maximum flow rate)	46kPa	60kPa	85kPa
Responsivity	Sampling 1s		
*1 Power supply	DC24V±10%		
Current consumption	Max. 30mA (Current output Max. 50mA)		
*2 Alarm output	Maximum load current	Max. DC 100mA	
	Maximum applied voltage	Max. DC 40V	
	Output mode	A or B output (select one)	
*3 Analog output (while ordering select only one output)	Voltage output	0~10V	
	Current output	4~20mA	
Display	Alarm: 2colors LED		
Certification, regulation	RoHS		
Wetted material	Body PPS, FKM	Adapter SUS304	
Adapter size	Rc3/8" Quick fitting		
Weight	155g		

*1 Voltage more than specified on the table will damage the product.
*2 Default setting of alarm output is 5L=2.5L/min, 10L=5L/min, 30L=15.0L/min.
*3 Analog output--After input the power, green LED will be on. Do not adjust(touch) the volume after shipping.

Wiring (interface)

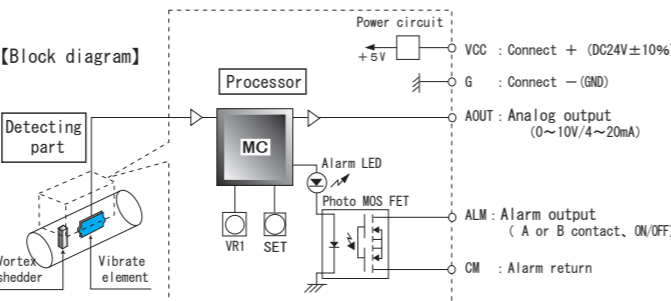

[cable functions]

Sign	Color	Name	Direction	Characteristic	Output selection	Operation and usage
VCC	Red	Connect +	PSL ← Equipment	DC24V±10%		Connect +side of power supply. Supply +24V to PSL.
G	Black	Connect -	PSL ↔ Equipment			Connect -side of power supply. It is GND (0V) of PSL. It is -line of analog output.
AOUT	White *	Analog output	PSL → Equipment	0~10V 4~20mA	**	Flow rate is changed to the electric signal and transmitted to the device. *line is for analog output.
ALM	Yellow *	Alarm output	PSL ← Equipment	Photo MOS FFT (A) Photo MOS FFT (B)	**	Alarming signal to equipment. (A) flow rate ≥ alarm value : ON (B) flow rate < alarm value : ON
CM	Blue *	Alarm return	PSL → Equipment	No need of earth (COM)		Alarm output return circuit. Independent from GND

*Default setting is one of outputs at the time of shipment.

*White wire is spare wire when alarm output, yellow and blue are spare wires when analog output.

⚠ Contact between the spare wires or between wires and external equipment could cause accident or damage. Please insulate each wire when used.

Output signal

1. Analog output

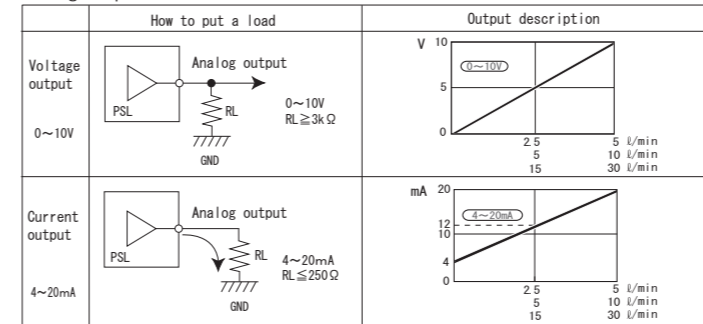

2. Alarm output

The diagram below shows how to put a load. There is no polar character within the range in rating voltage or current.

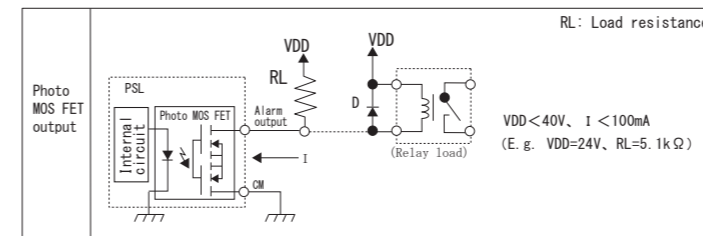

Procedures

The diagram below shows a control panel on the top of the body

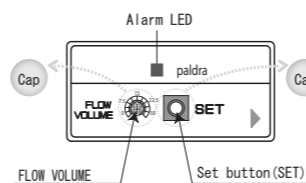

1. Take a cap out
2. Set a alarm value with a screw
3. Press a set button.
4. LED light confirms the Deviation from set value.

[Power on]
This flow meter does not have a switch to power on. Connect a red wire, +V and black wire, 0V with 24V. Then LED will be on.

Alarm settings

*table 1 explains definition of alarm output and LED. While ordering select only one output

Remove the caps and you will see the volume and set button. *you can set a alarm only when you chose a alarm output..

1. Power on (DC 24V) then LED (red or green) will be on.
2. Rotate the arrow with a plastic screw, for example, and set a alarm value.
3. Press SET to confirm the settings. Micro computer inside of the flow meter memories' it. To change the value, rotate the arrow and press SET again.
4. Alarm is signaled with LED (D1).

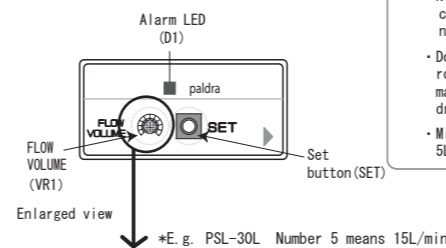

[Indication of divisions]

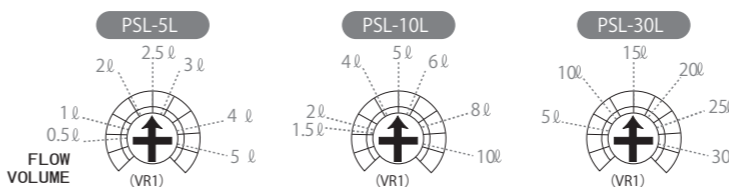

<table 1> Description of alarm output and LED lights

Alarm	A	B
More than set value	GRN ON	RED ON
Less than set value	RED ON	GRN ON
	OFF	OFF

*A internal circuit of alarm output is MOS-FET. ON: conduction and OFF: No conduction

- No need to set anything when you chose a analog output. Please do not press or rotate anything.
- Do NOT use metallic screw driver to rotate or press to set. Use a insulating material, for example a plastic screw driver.
- Minimum setting values are: 5L=0.5L/min, 10L=1.5L/min, 30L=5L/min

[Flow rate set value diagram]

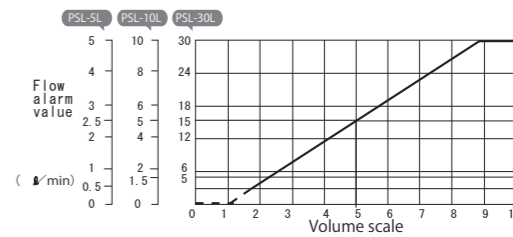

Note: There is only the numbers from 0 to 10 on the volume. Please set the value referring to this diagram.

Connections

- ※ At the time of shipment adapters and quick fastener has enclosed separately.
- ① Adapter is Rc3/8 Female. Keep the adapter hold and screw the fitting.

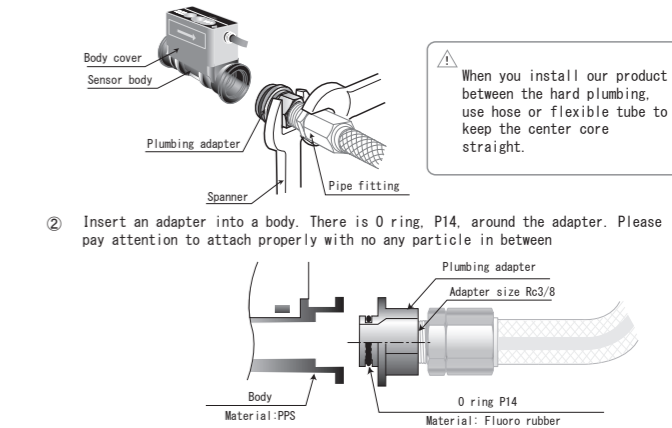

- ③ Put quick fastener on the adapter until the adapters are locked between the gap of the fastener. Make sure it is tightly locked.

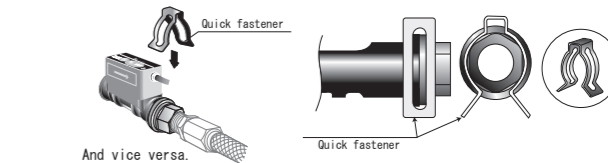

- A straight pipe length needs min. 7D on upper stream and 5D on down stream to keep the accuracy.
- Please do not do the plumbing (Put and orifice) sudden changes in the size of piping upstream.
- Install valves, bifurcations, gages etc. on down stream.
- D=adapter size, 5L: 4.1mm, 10L: 5.8mm, 30L: 10mm
- Please beware of the direct load/pressure on the flow meter (PPS). It could cause leaking or damages.
- Do NOT grab or press the cover very hard when you are connecting(plumbing)

Storage

- Please store our products under environments as follows.
 - Where it is NOT exposed to rain or water.
 - Where it is NOT exposed to direct sunshine.
 - Where it is NOT exposed to dust.
 - Where it is NO vibration or impact.
 - Where it is static-free.
 - Where ambient environment is controlled between 0-50 degree Celsius without dewing and freezing.
- *Please store our products as you received.

Warranty and disclaimer

- We are not responsible regarding the accident that occurred from the incorrect use of our products or possible lack of information in this document.
- Warranty period of our product is one year from the received date of the product(s).
- If the claimed defect of specifications or materials in the period of the warranty are verified with a document, we will replace free of the product(s). This warranty covers only our products. This warranty does not cover direct or/and indirect damages like lost, damages or injurers etc. caused by defected products.
- We supply a replacement on request. And an inspection of the equipment does not disclose any defect causing by us, the replacement will be charged.
- *The replacement is the same product as we sold but we would supply a different product for certain reasons.
- *It refers the case which we do not have any responsibility.
 - In use out of non-compliance regarding this instruction manual.
 - Negligence in use.
 - Disassembling or conversion of our products.

About instructions manual

- It is not allowed to reprint or reproduce a part or full instruction manual without any prior permission by us.
- All the contents of instruction manual are correct at the date of publication and are subjected to change without notice. Please save the latest issue of our products.
- The contents of the outline and specification of the flow sensor in this operating manual has followed as per the standards. Care must be carried out properly while using sensor with a proper lay-out and consideration against external condition.
- Please contact us if you acknowledge any mistakes or unlisted information in this instruction manual.

*The design, dimensions and specifications of the product in the catalog were correct at the date of publication and are subjected to change without notice.

Produced by **Regal Joint Co., Ltd.**

1-9-49 Onodai Minami-ku Sagami-hara-shi, Kanagawa, Japan 252-0331

TEL +81-(0)42-756 7411 (Sales)

FAX +81-(0)42-752 2004 (Toll Free)

URL <http://www.rgl.co.jp>

4nd issue: August 2014