

Impeller flow meter

RGL JOINT Tel +81-42 756 7411
 Fax +81-42 752 2004
 REGAL JOINT CO., LTD.
 1-9-49 Onodai Minami-ku
 Sagamihara-shi Kanagawa Japan
 252 0331

URL <http://www.rgl.co.jp>

Out line

This Flow sensor Type FS-N can be used to output the electric pulse signals the number of which is proportional to the flow rate. When the fluid is flowing, LED lights.

FS-N Instructions Manual

FS-3N/10N/30N



Before using our product.

- Please read carefully the instructions before you use our product.
- Please follow the procedures, conditions and cautions as per the instructions.

Safety information

Warning	Mishandling could cause injury or even death at drastic conditions.		Never do it.
Caution	Mishandling could cause disability, fire or other damages to the building or properties.		Do it only with following instructions.

Warning

Unusual or faulty conditions

- If you continue using our product under the unusual or faulty connections or conditions like as smoking, foul smell, unstable and malfunction, it could cause fire or accident. Cut the power supply immediately and contact to us. Do not try to repair the product yourself.

Working environments

In the humid or dewing environment, it could cause accident or damage because of moisture.

In the vibration, impulsion or pulsation environment, it could cause malfunction, some accident or damage.

Our products are NOT explosion-proof. Do not use in the dangerous environment with flammable, explosive, or corrosive gas. Do not use outside. This product is only for inside.

Installation in high temperature environment as near to heat instruments could cause some accident or damage as the heat instrument will led the temp rise inside the flow meter. Please use our product as instructed in the manual.

Caution

Cables

- Please do not put heavy objects on the cables or pull the cables from flow meter body, it could cause accident or damage.
- External device and cable or cable to each other, do not use come into contact with, you cause an accident or malfunction. Please use it after the insulation process one by one.
- Please follow the Instructions for "wiring", "Output signal", "how to put a load output", "Specifications" other wise, it could cause accident or damages.

Working environments

Magnetic power, electromagnetic wave, radioactive ray or ultraviolet rays could cause accident or damage.

Electric corrosion or static electricity could cause accident or damages.

In electrically noisy environments as like around high-frequency power source could cause accident or damages.

- Install the filter upper flow/Inlet to clear some piece of metal or small objects if needed.
- Remove the bubbles in the fluid for accurate measurement of flow rate.

Packaging and carrying.

- Do not drop. Handle with care otherwise The flow meter could damage or cause malfunctioning.

Installations

- Mind your fingers while plumbing a sensor or you could get injured.

Others

- Please contact us if you received damaged or deformed product.

Maintenance

- Contact us for overhauling, adjusting or repairing. Please make sure not to touch an electronic substrate inside of flow meter.

- Only a person who has technical knowledge and experiences could do plumbing, wiring, maintenance or overhauling.

- While installation or maintenance please shut off the power and water supply for your safety.

Storage

- Please store our products under environments as follows.

- Where it is NOT exposed to rain or water.
- Where it is NOT exposed to direct sunshine.
- Where it is NOT exposed to dust.
- Where it is NO vibration or impact.
- Where it is static-free.
- Where ambient environment is controlled between 0-40 degree Celsius without dewing and freezing.
- Please store our products as you received.

Warranty and disclaimer

- We are not responsible regarding the accident that occurred from the incorrect use of our products or possible lack of information in this document.

- Warranty period of our product is one year from the received date of the product(s).
- If the claimed defect of specifications or materials in the period of the warranty are verified with a document, we will replace free of the product(s). This warranty covers only our products. This warranty does not cover direct or/and indirect damages like lost, damages or injurers etc. caused by defected products.

- We supply a replacement on request. And an inspection of the equipment does not disclose any defect causing by us, the replacement will be charged.

*The replacement is the same product as we sold but we would supply a different product for certain reasons.

*It refers the case which we do not have any responsibility.

In use out of non-compliance regarding this instruction manual. Negligence in use.

Disassembling or conversion of our products.

About instructions manual

- It is not allowed to reprint or reproduce a part or full instruction manual without any prior permission by us.

- All the contents of instruction manual are correct at the date of publication and are subjected to change without notice. Please save the latest issue of our products. Please get our website at ([URL http://www.rgl.co.jp/](http://www.rgl.co.jp/)) the latest version.

- The contents of the outline and specification of the flow sensor in this operating manual has followed as per the standards. Care must be carried out properly while using sensor with a proper lay-out and consideration against external condition.

- Please contact us if you acknowledge any mistakes or unlisted information in this instruction manual.

*The design, dimensions and specifications of the product in the catalog were correct at the date of publication and are subjected to change without notice.

Configuration and Dimensions

A magnet is built-in the runner that rotates corresponding to flow rate and its magnetism is perceived by magnetic Sensor. Flow rate is to be calculated by changing magnetism and is output comparing with the set value and, at the same time, the existent flow rate is converted into pulse output as a result.

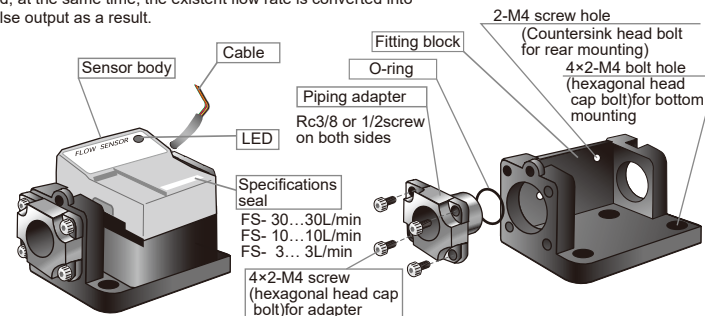

Fitting block can be fastened by means of either bottom fitting (by using 4 Nos. of M4 of hexagonal head cap bolt). For rear fitting (by using 2Nos. of M4 of a small countersinking screw) or by means of pipe construction depending on fitting way.

[Block size]

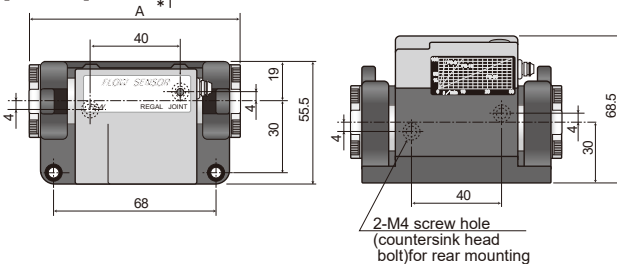

*1 Dimension shown in bracket () may differ depending upon the size of the adapter.

[A Dimension Table]

Adapter connection size	A dimension	
	BsBM	SUS
Rc3/8	92	98
Rc1/2	115	115

Specifications

Model	FS-3N	FS-10N	FS-30N
Rated flow range	0.5~3.0L /min	1.5~10.0L /min	5.0~30.0L /min
Applicable fluid	Industrial water, Water	*4 Various liquids	
Detection type	Impeller type		
Fluid temperature	0~60°C, *4 0~90°C (No freezing, no dewing)		
Operating temperature	0~40°C (No freezing, no dewing)		
Accuracy *2	±2.5% F.S.		
Max. working pressure	1.0MPa *4 0.5MPa		
Power supply voltage *3	DC12V±5% or DC24V±10%		
Current consumption	25mA		
Cable	AWM20276 (3cores 0.2mm ² 500mm)		
Pulse output	Max. load current	Less than DC100mA	
	Max. applied voltage	Less than DC40V	
	Output mode	MOSFET	
Frequency outputs	0~43Hz		0~121Hz
	0~93Hz		
	0~121Hz		
Standard	RoHS compliance (Only SUS adapter)		
Wetted material	Polyacetal, Polyamide *4 Fluororesin, Ceramic		
Connection material	SUS or BsBM (Ni plating) *4 Fluororesin		
O-ring for sealing	Chloroprene or Fluoro rubber		
Orifice diameter	φ5	φ7	φ10
Adapter connection size	Rc3/8 or Rc1/2 *5 φ10×12mm		
Weight	Approx. 380g		
Mounting position	Free		
Flow direction	Both direction		
Construction	Water drip-proof against electronic circuit		

- *2 Since F.S.(Full scale) is { 30L/min, 10L/min, 3L/min }, the deflection could be of { ±0.75L/min, ±0.25L/min, ±0.075L/min. }
- *3 Power supply is transmitted of either DC 12V or DC 24V on the time of the order.
- *4 In case of fluorine resin body.
- *5 Fluororesin body When the aperture is optional.

Flow Rate Characteristics

[Pressure Loss Diagram]

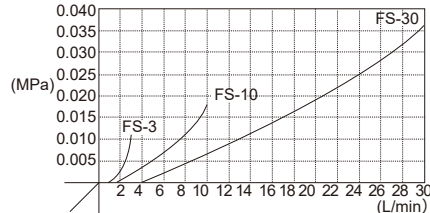

Following diagram shows pressure difference between primary and secondary pressure at 0.29MPa of original pressure.

Connections

[Fig.1]

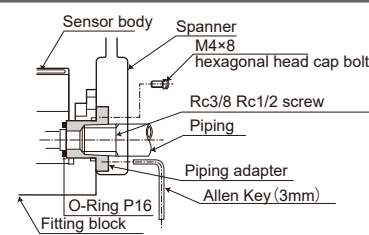

[Fig.2]

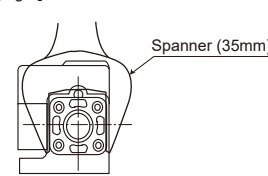

- Piping connection must be done by means of screw into the piping adapter or by using KANTOUCH coupling made by REGAL JOINT CO., LTD.
- Caution while fitting piping material When applying a spanner (35mm) to fit the piping material, never fail to put it on the outer circumference of the piping adapter.

Caution Putting the spanner directly on the fitting block might cause a breakage of the flow sensor (see Fig.2).

- Inner diameter of the piping adapter is Rc 3/8" or Rc1/2" .
- The piping adapter is fixed on the fitting block by using 4 Nos. of the hexagonal head cap bolt M4×8. Use a 3mm hexagonal screw driver or L-Type wrench for mounting and detaching the dapter.

Caution O-Ring (Type P-16) is inserted to the sealing surface between the Flow sensor body and Piping adaptor.

Do not forget to insert it and take care of twisting and striking dust to it as it could affect the result in accuracy.

Warning

- Fitting the sensor body without O-rings might cause leakage.
- Please install the water filter in the pipe in case of handling impure water.
- Do not use air while driving out the water from water pipes. It could lead the failure of flow sensor.

Wiring (Interface)

Connect the cable with the junction terminal and connector by means of soldering or crimping tool. It is recommended to use a cable with #24~#28 of the core size for connector.

[Cable functions]

Color	Name	Characteristic	Output selection	Operation and usage
Red	Power Supply(+)	DC12V±5% DC24V±10%	Alternatively	Connect +side of power supply. Supply +24V or +12V .
Black	Power Supply(-)			Connect -side of power supply. It is GND(0V) . It is common ground line of Pulse output.
White	Pulse output	MOSFET		

- Warning** (1)Because it becomes the cause of accidents and failure external equipment and cables are in contact with each other or cable, do not use, please use it after the insulation process one by one.
- (2)Voltage more than specified on the table will damage the product.
- (3)Anti-polar connection might result destruction of the flow sensor.
- (4)Pulse output It will destroy the output line is a short circuit in the power supply.

[Output signals]

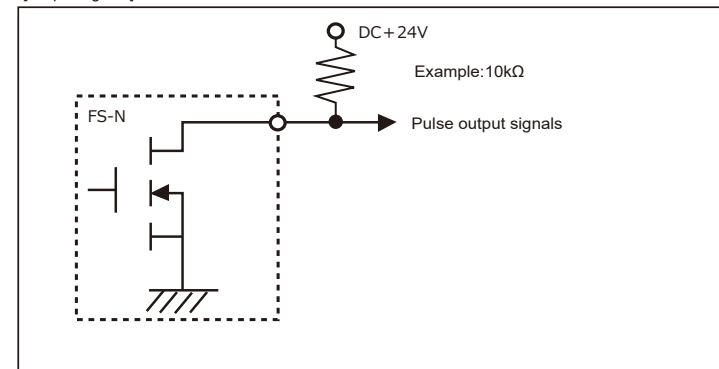

Output signals

[Pulse output](open collector)

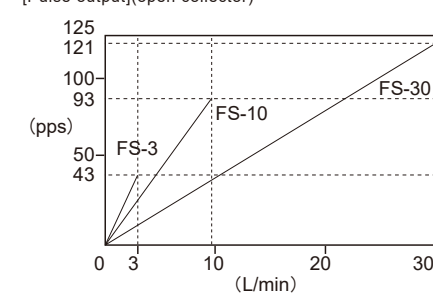

The above graph is a guide.

Operating method

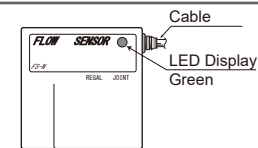

- Connections Go to the section of "Connections", This ensures that your piping.

- Electrical wiring The next step is to connect to (controller / sequencer) the section "Wiring", the device cable.

- Power activation If the direct-current power supply is supplied through a cable from the outside, the sensor becomes operational. (There is no power switch on the sensor) So, if electric water through a pipe, it lights flow indicator (green LED) or flashing. Is proportional to the flow rate, number of flashes looks still lit at a flow rate above a certain. As a guideline,

- FS-3N Lit with about 1.5L / min or more
- FS-10N Lit with about 3.0L / min or more
- FS-30N Lit with about 6.0L / min or more

You can see that it is by looking at (or lights) flashing indicator lamp flow, fluid is flowing can be visual, is in the operating state sensor.

- Cable The flow sensor is provided with 3 cores cab tire cable consisting of 2 cores for DC power supply to the sensor itself and 1 cores for Pulse output. Pulse output power and uses a common ground wire.

Maintenance

[Removing Sensor Body]

- Turn the power supply OFF (Power supply cable must be taken out, because this flow sensor is not provided with power supply switch).
- Loosen 4 Nos. of M4 screws for the adapter (hexagonal socket head cap bolt M4×8) by using a Allen key. (see following figure)
- Slide the Flow sensor body slightly towards the loosened adapter as directed above. (2)
- Some space appears between the adapter and flow sensor body. Sliding the sensor body towards flowing direction, the sensor body can be pulled out towards the upward direction of the block or towards the side. At that time, care must be taken that fluid inside piping might run over.
- Installation can be done in reverse side of the flow sensor.

Caution Be careful that O-rings on both sides do not fall down.

* Please contact us if you have any questions or concerns of maintenance on. If the failure dismantling of the product, due to the decomposition is found, I will not be responsible.

REGAL JOINT CO., LTD.
 RGL JOINT
 Tel +81-42 756 7411
 Fax +81-42 752 2004

1-9-49 Onodai Minami-ku
 Sagamihara-shi Kanagawa Japan
 252 0331
 URL <http://www.rgl.co.jp>